

TORRETTE TR-ED RANGE HOT FUMES ROOF FANS

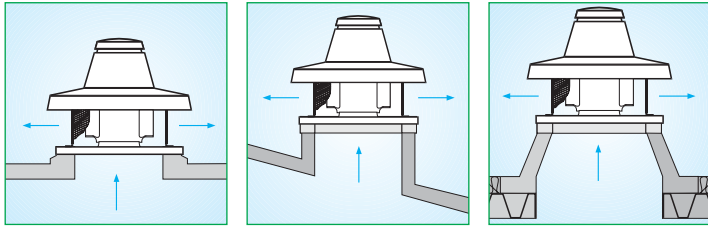

- Suitable for mounting on flat roofs of commercial, industrial buildings and blocks of flats, etc.
- Delivery: up to 13.500 m³/h
- Operating temperature: from -25°C to + 90°C under continuous operation. Engineered for 2 hours continuous operation with fumes at 400°C.
- Motor insulation class H with IP55.
- Asynchronous induction motor, thermally protected, standard UNELMEC B5 size, ball bearing mounted rotor.
- Galvanised steel sheet fan with self-cleaning, backward curved blades, self-ventilating, die cast aluminium hub, clockwise rotation (intake view).
- Painted anti-touch steel ring protection grille.
- Certified by TUV according to EN 12101-3 (at max speed). Certification numbers: TRM models: 0036 CPD RG03 01 TRT models : 0036 CPD RG03 02
- Streamlined cross-section intake port, made of sheet steel and finished in protective polyester paint.
- For long term safety each unit has a safety cable to anchor it to the base.
- Single phase models can be controlled by an optional speed controller. Three phase models have two speeds which can be selected with an optional speed switch.
- Sound power and pressure levels conforming to ISO 3744.

Wiring diagrams shown on page XXXIX.

M: Monophase (Single phase) 220-240 V - 50 Hz
T: Triphase (Three phase) 380 - 415 V - 50Hz

Product	Code	V-50 Hz	W*	A*	Poles	Rpm	Delivery		P max		Lp dB(A) (3 m)*	kg	Insulation	IP	max °C
							m ³ /h*	l/s*	mm H ₂ O*	Pa*					
TRM 10 ED 4P	15039	220-240	100/110	0.46/0.46	4	1395	1000	278	20	196	56	18.5	⊕ cl.I	55	90 (continuous operation)
TRM 15 ED 4P	15041	220-240	130/140	0.59/0.58	4	1315	1400	389	24	235	58.5	19.0	⊕ cl.I	55	
TRM 20 ED 4P	15043	220-240	260/270	1.21/1.18	4	1375	2200	611	34	334	59	33.0	⊕ cl.I	55	
TRM 30 ED 4P	15046	220-240	400/420	1.87/1.78	4	1285	3100	861	40	392	67	35.0	⊕ cl.I	55	
TRM 50 ED 4P	15048	220-240	700/720	3.30/3.10	4	1288	4500	1250	52	510	72.5	40.0	⊕ cl.I	55	
TRM 70 ED 4P	15080	220-240	1000/1200	4.50/4.30	4	1415	5800	1611	65	638	77	80.0	⊕ cl.I	55	
TRT 10 ED 4P	15040	380-415	95/100	0.23/0.24	4	1400	1100/ 890	306/ 247	21/ 17	206/ 167	56	18.5	⊕ cl.I	55	
TRT 15 ED 4P	15042	380-415	120/130	0.26/0.27	4	1345	1400/ 1100	384/ 306	24/ 16	235/ 157	58.5	19.0	⊕ cl.I	55	
TRT 20 ED 4P	15045	380-415	260/270	0.52/0.53	4	1384	2200/ 1800	611/ 500	34/ 24	334/ 235	59	33.0	⊕ cl.I	55	
TRT 30 ED 4P	15047	380-415	400/420	0.75/0.75	4	1355	3100/ 2555	861/ 710	43/ 30	422/ 294	67	35.0	⊕ cl.I	55	
TRT 50 ED 4P	15049	380-415	670/690	1.22/1.21	4	1380	4500/ 3800	1250/ 1056	52/ 38	510/ 373	72.5	40.0	⊕ cl.I	55	
TRT 70 ED 4P	15081	380-415	1040/1090	2.0/2.0	4	1440	6000/ 5300	1667/ 1472	67/ 52	657/ 510	77	78.0	⊕ cl.I	55	
TRT 70 ED 6P	15082	380-415	580/600	1.3/1.3	6	950	6000/ 5300	1667/ 1472	38/ 30	373/ 294	74	81.0	⊕ cl.I	55	
TRT 100 ED 4P	15083	380-415	1860/1950	4.2/4.9	4	1420	9100/ 8300	2528/ 2306	84/ 72	824/ 706	84	81.5	⊕ cl.I	55	
TRT 100 ED 6P	15084	380-415	1090/1130	2.3/2.4	6	950	8600/ 7550	2389/ 2097	47/ 38	461/ 373	77	114.0	⊕ cl.I	55	
TRT 100 ED 8P	15085	380-415	820/860	1.9/2.0	8	715	9200/ 8200	2556/ 2278	34/ 28	334/ 275	71	124.0	⊕ cl.I	55	
TRT 150 ED 6P	15086	380-415	1850/1930	3.5/3.4	6	930	12800/ 11000	3556/ 3056	59/ 42	579/ 412	80	125.0	⊕ cl.I	55	
TRT 150 ED 8P	15087	380-415	1470/1510	3.0/3.0	8	715	13500/ 11600	3750/ 3222	42/ 34	412/ 334	74	129.0	⊕ cl.I	55	

* At max speed.



Easily installed on all types of roof. For extracting low dust, acid-free and non-corrosive air only. Maximum air temperature for continuous operation is 90°C. Not suitable for installation in ducts located directly above fireplaces or burners.

Dimensions (mm)

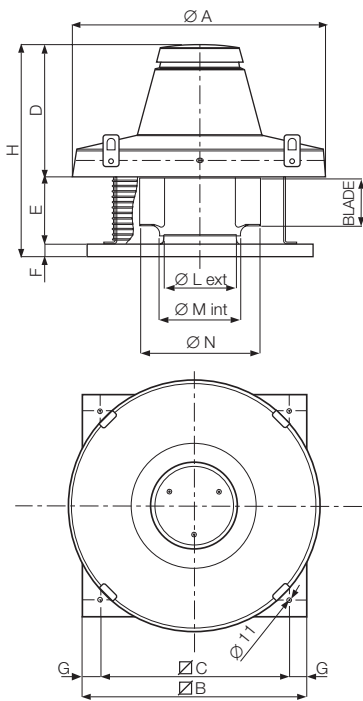

	Ø A	Ø B	Ø C	D	E	F	G	H	Ø L	Ø M	Ø N
TRM 10 ED 4P	600	410	357	309	166	38	26.5	513	183	187.5	280
TRT 10 ED 4P	600	410	357	309	166	38	26.5	513	183	187.5	280
TRM 15 ED 4P	600	410	357	309	166	38	26.5	513	206	211	315
TRT 15 ED 4P	600	410	357	309	166	38	26.5	513	206	211	315
TRM 20 ED 4P	780	550	500	397	226	38	25	661	231	236.5	355
TRT 20 ED 4P	780	550	500	397	226	38	25	661	231	236.5	355
TRM 30 ED 4P	780	550	500	397	226	38	25	661	260	265.5	400
TRT 30 ED 4P	780	550	500	397	226	38	25	661	260	265.5	400
TRM 50 ED 4P	780	550	500	397	243	38	25	678	292	298	450
TRT 50 ED 4P	780	550	500	397	243	38	25	678	292	298	450
TRM 70 ED 4P	1015	830	750	449	283	38	40	770	328	335	504
TRT 70 ED 4P	1015	830	750	449	283	38	40	770	328	335	504
TRT 70 ED 6P	1015	830	750	449	283	38	40	770	365	375	562
TRT 100 ED 4P	1015	830	750	449	283	38	40	770	365	375	562
TRT 100 ED 6P	1165	980	900	605	383	38	40	1026	415	421	635
TRT 100 ED 8P	1165	980	900	605	383	38	40	1026	415	472	715
TRT 150 ED 6P	1165	980	900	605	383	38	40	1026	465	472	715
TRT 150 ED 8P	1165	980	900	605	383	38	40	1026	520	529	805

Accessories (description and data on pages 142-145).

Model		Code	Products
	TR-CU 10/15 (sub-frame)	22511	15039 - 15040 - 15041 - 15042
	TR-CU 20/30/50 (sub-frame)	22512	15043 - 15045 - 15046 - 15047 - 15048 - 15049
	TR-CU 70/100 (sub-frame)	22539	15080 - 15081 - 15082 - 15083
	TR-CU 100/150-6P/8P (sub-frame)	22540	15084 - 15085 - 15086 - 15087
	TR-ED-G 10/15 (protective grille)	22700	15039 - 15040 - 15041 - 15042
	TR-ED-G 20/30/50 (protective grille)	22710	15043 - 15045 - 15046 - 15047 - 15048 - 15049
	TR-G 70/100 (protective grille)	22506	15080 - 15081 - 15082 - 15083
	TR-G 100/150-6P/8P (protective grille)	22507	15084 - 15085 - 15086 - 15087
	TR-CVT (three phase speed controller)	22910	For all TRT models
	IRM 30 (single phase speed controller)	12921	15039* - 15041*
	IRM 40 (single phase speed controller)	12922	15043* - 15046*
	IRM 50 (single phase speed controller)	12928	15048* - 15080*
	IRT 15 (three phase speed controller)	12923	15040* - 15042* - 15045*
	IRT 35 (three phase speed controller)	12924	15047* - 15049* - 15081* - 15082* - 15084* - 15085*
	IRT 40 (three phase speed controller)	12927	15083* - 15086* - 15087*

* Not suitable for hot fumes extraction when regulated with speed controller

Pressure/performance curves

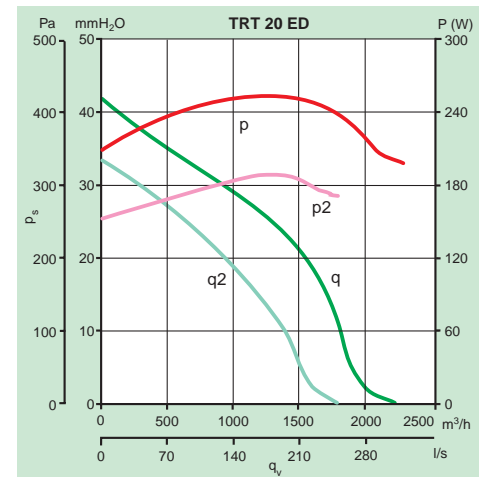
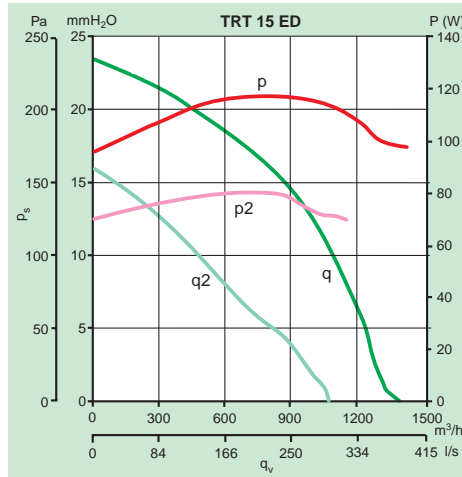
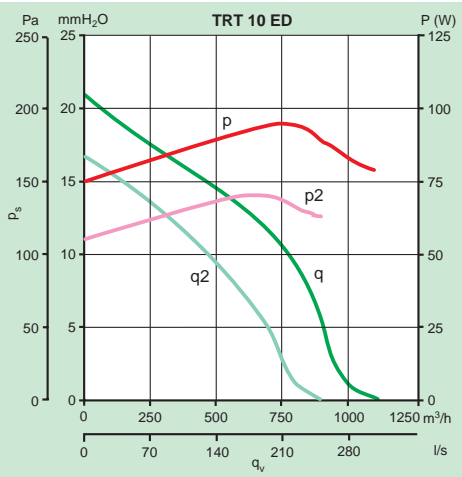
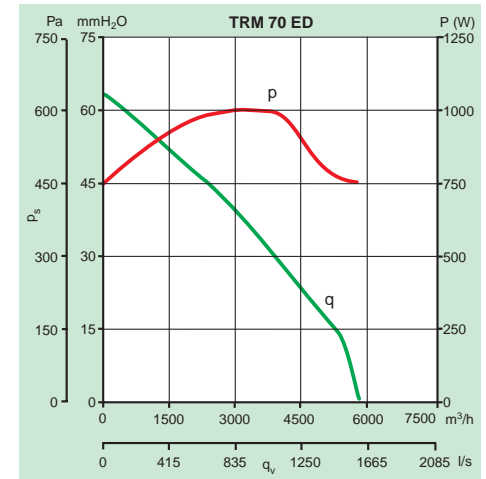
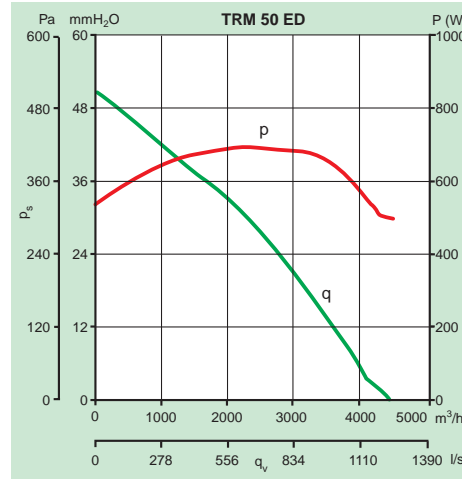
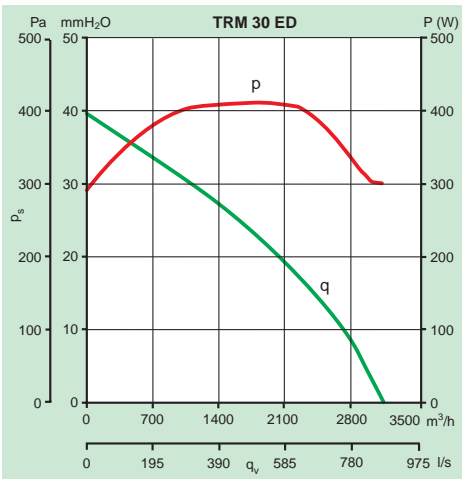
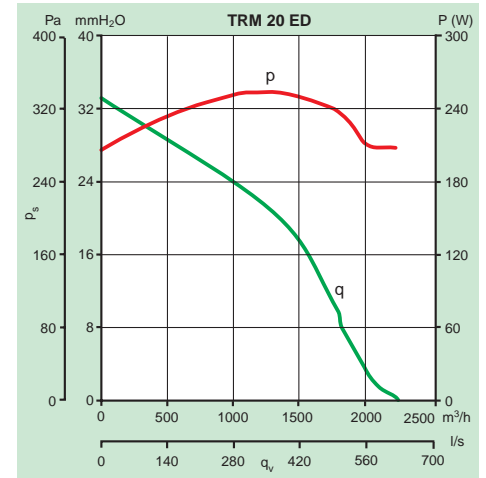
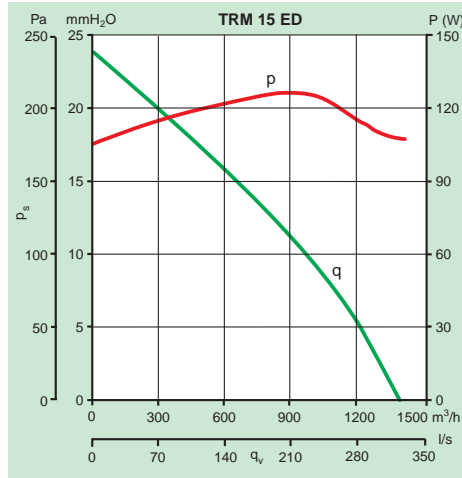
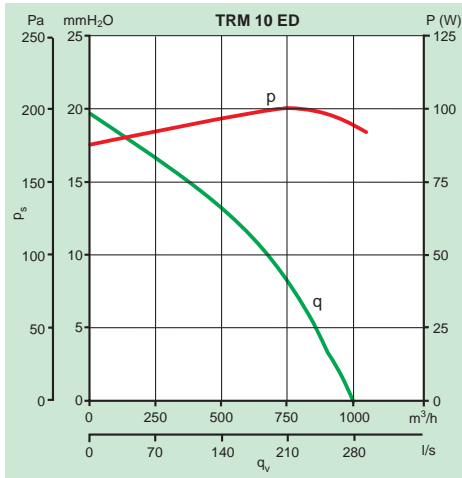

Pressure/performance curves

